

# DISPOSAL of GOLD Components

Grease One-Way Logistics and Distribution

Disposal Guide

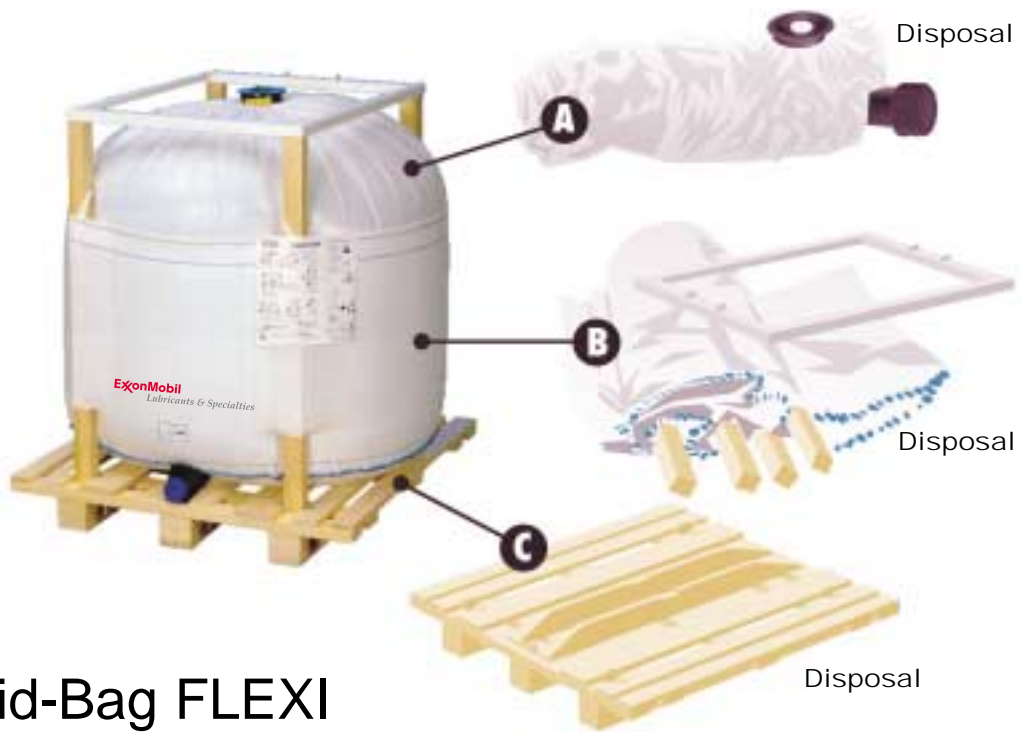



## Fluid-Bag FLEXI

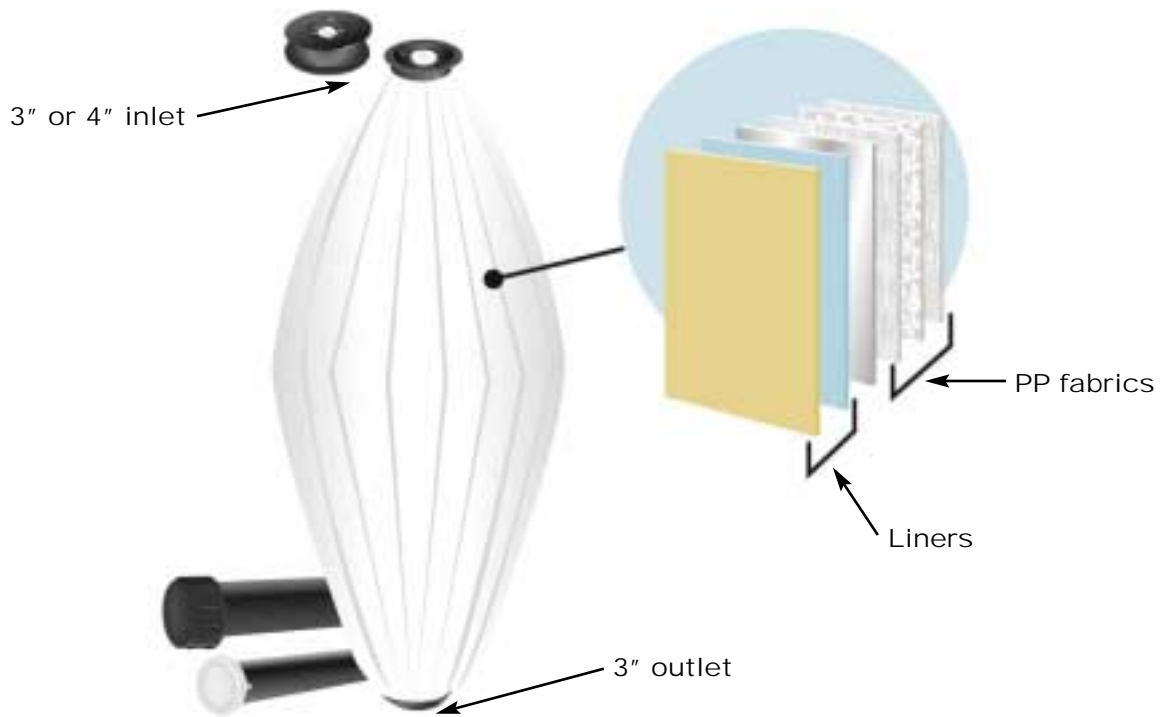

## Inner Container

# A. Disposal of Inner Container



- Incineration (when no problem with grease residue)
  - Disposal
  - Handling as problem waste (due to grease residue)
- Weight 7.58 – 14.35 lb (plus grease residue)

or

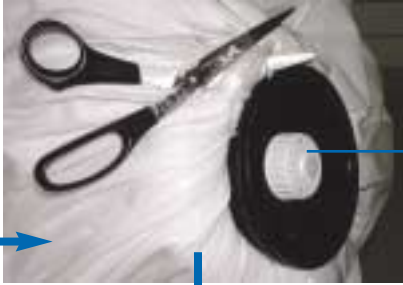

The inner container can easily be split into pure PP fabric (3.17 – 3.44 lb) and a double or triple walled inner liner with HDPE valves, 1.23 – 4.28 lb (plus grease residue).

Liner materials: LDPE, LLDPE, HDPE and PA.



- Incineration (when no problem with grease residue)
  - Disposal
  - Handling as problem waste (due to grease residue)
- Weight 1.23 – 4.28 lb (plus grease residue)

- Incineration
  - Regranulation
  - Disposal
- PP material: 3.17 – 3.44 lb

or



- Incineration
  - Regranulation
  - Disposal
- Liner material: 1.50 – 4.28 lb (single or double walled liner)



- Incineration (when no problem with grease residue)
  - Disposal
  - Handling as problem waste (due to grease residue)
- Weight 2.67 – 6.37 lb (plus grease residue)

## B. Disposal of Outer Container/Frame



- Incineration
- Regranulation
- Disposal
- Reuse

Total weight, Flexi 11.68 – 13.00 lb  
Materials: PP and LDPE, hardwood

or



- Incineration
- Regranulation
- Disposal

Weight 2.54 – 2.87 lb  
Materials: PP and LDPE



- Incineration
- Reuse
- Raw material

Total weight, Flexi 13.22 – 15.43 lb  
Materials: hardwood

- Reuse / Disposal

Weight 10.14 lb  
Material: galvanized/painted steel

## C. Disposal of Pallett



- Incineration
- Reuse
- Disposal

Weight 48.50 – 59.52 lb  
Material: untreated wood (heat treated, IPPC HT/KD 56/30)

or

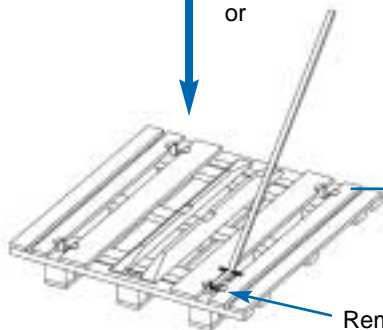

Raw material for wooden products

Wood material 46.29 – 52.91 lb

Removal of metal inserts